

VARUN IMPEX
Solutions for Furniture Industry

WARDROBE FITTINGS

INDEX



Walk-in-Wardrobe

04-05



Sliding Wardrobe
Bridge System 500

06-07



Smart Cube

08-09

VARUN IMPEX

Is characterized by the different solutions it can offer and offer to its customers. The company has technologies for cleaning and oxidizing aluminium; present in sectors such as furniture, home automation and automotive. The intent is to satisfy the most diverse needs thanks to the efficiency of the industrial process.

Varun Impex recognizes the importance of environmental protection and sustainable production; for this reason, over the years it has invested with the aim of reducing the environmental impact in the territory.

Social responsibility is a concept of **Varun Impex** philosophy: A choice that reflects the desire to respect the territory in which it has developed and above all to contribute personally within the social fabric in which it operates. Aware of its function in the community, has adopted a policy aimed at safeguarding the environment for authentic sustainable development. With this aim, over the years it has developed a series of profitable and continuous collaborations with some associations and realities in the area, different from each other, but united by concreteness and goodwill.



Walk-in-Wardrobe



Aluminium Bar: Code 3520

Dimension: L: 3000mm x D: 53mm x W: 16mm

Product Feature:

*Aluminium bar with length 3000mm.

Application: Wardrobes, Shelving, Bookshelf, TV Entertainment units, Office/desk, Shop.

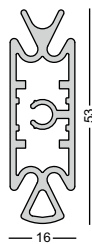

Glass Shelf Bracket: Code 3522

Product Feature:

- *It is used with shelf holder.
- *To be use in conjunction with flat shelf holder.
- *1 set consist-glass shelf bracket.
- *1 anti scratch plate.
- *Two transparent gasket & 1 screw.

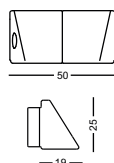
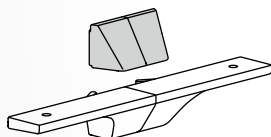

Shelf Holder: Code 3521

Dimension: L: 160mm x D: 22mm x W: 22mm

Product Feature:

- *Shelf holder 160mm.
- *Able to attach wooden shelf & drawer.
- *Anti scratch plate.

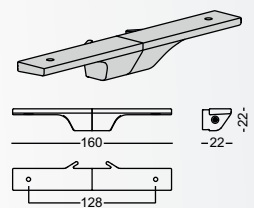

Adjustable Foot: Code 3523

Product Feature:

- *Foot can be adjusted by max. 15mm in length.
- *1 set consist-1 foot bracket, 1 self threading screw and 1 adjustable foot.

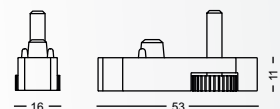
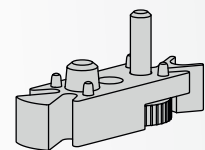

Corner Joint Wall Connector: Code 3524

Product Feature:

*1 set consist-one corner joint & 1 wall connector.

Application: It is used with from wall to wall floor to wall corner joint.

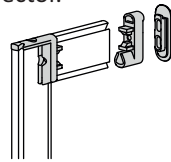

Tube Holder: Code 3529

Product Feature:

*Fully adjustable in height.

*Suitable for wardrobe rail.

Width: 15mm x Height 30mm

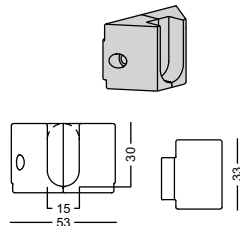

Intermediate Support: Code 3532

Product Feature:

*Can be positioned at any height.

*It's used for fix with ceiling connector and attach to the aluminium bar.

*Eliminates any effect ragged in aluminium bars large.

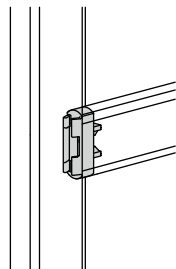

Sloping Shelf: Code 3428

Product Feature:

*Designed for wooden shelves only.

*Perfect to create shoe racks, magazine displays.

*Allows to create a shelf on all angles.

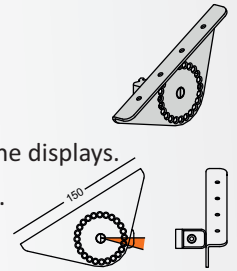

Desk Bracket: Code 3449

Dimension: W: 445mm D: 33mm H: 33mm

Product Feature:

*Drills directly into wall.

*Positioned up to the shelf holder with wooden shelf support available in Pairs.

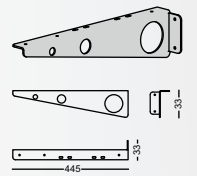

Walk In Wardrobe
is a Functional Space &
A Stylish Furnishing
Solution for your Home.
Different Ways of
Installation Allows System
to fit in all Spaces &
Create Functional &
Original Settings.



Sliding Wardrobe Bridge System 500

Bridge system 500 - Two door sliding size 8ft. x 8ft.

Bridge system 500 - Two door sliding size 9ft. x 9ft.

Product Feature:

- *Maximum capacity of 60Kg.
- *Suitable for both wooden or aluminium framed doors.
- *Available two door sliding doors mounted inside the cabinet with soft-closing dampers.
- *The aluminium frame profiles are designed to work with 4mm thick glass with standard gasket or up to 10mm wood panels without the gasket.
- *The aluminium frame profiles can be cut to suit the desired door sizes.



500 offers three different kind of vertical handle profiles. The profiles 010662 and 010884 work with the same accessories, while for the profile 010702 different accessories are available.



Junction Elements for the Horizontal Crosspieces Assembling

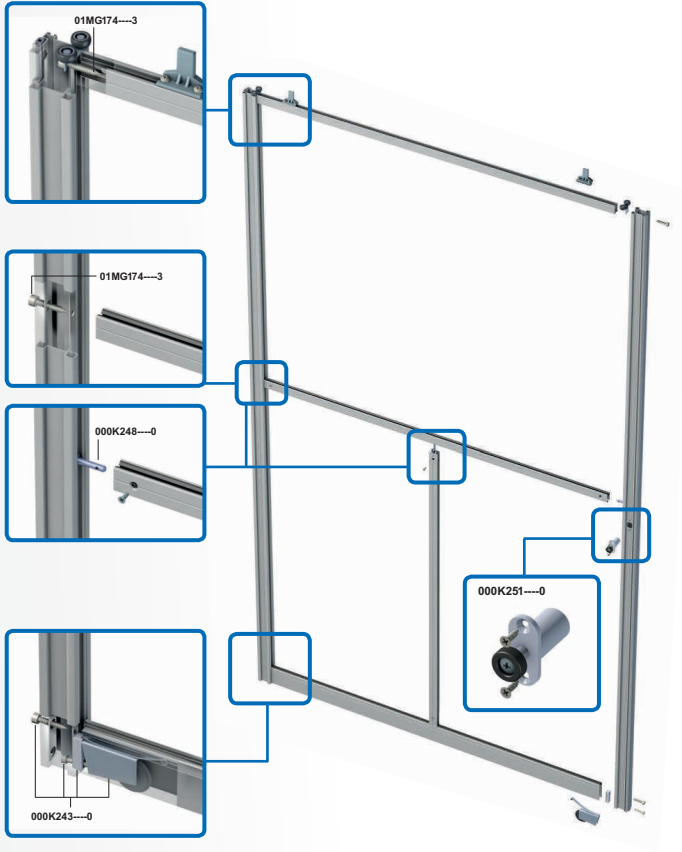

Soft-closing Dampers Insertion In The Upper Rail



TRADITIONAL STOPPERS INSERTION IN THE UPPER RAIL

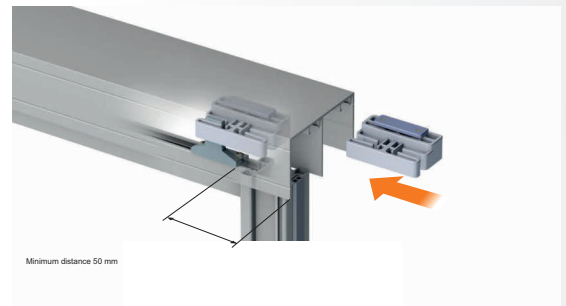

Calculation Formulas To Get The Door Sizes According To The Vain Measurement

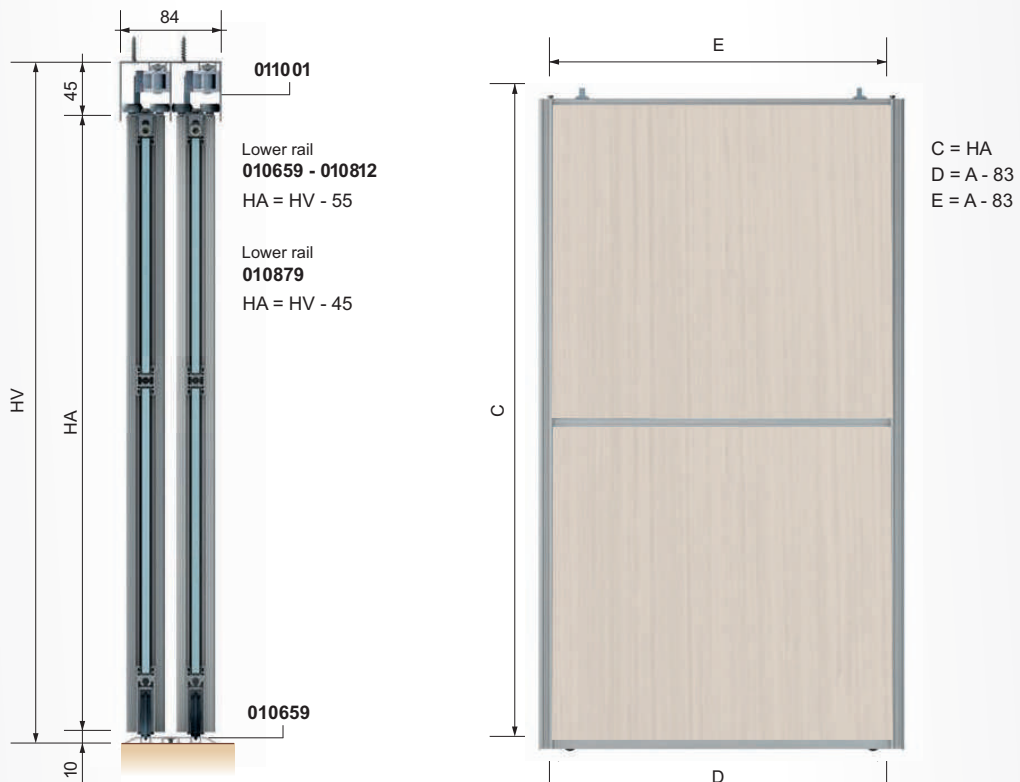

Smart Cube

Float is an extremely versatile aluminium system that allows you to create an endless range of furnishing and furnishing solutions.

Product Feature:

- 1. Only two aluminium profiles
- 2. Modularity
- 3. Quick mounting
- 4. Suitable for shelves from 4 to 19mm thickness
- 5. With glass safety lock
- 6. Available in different finishes
- 7. Profiles available in bars

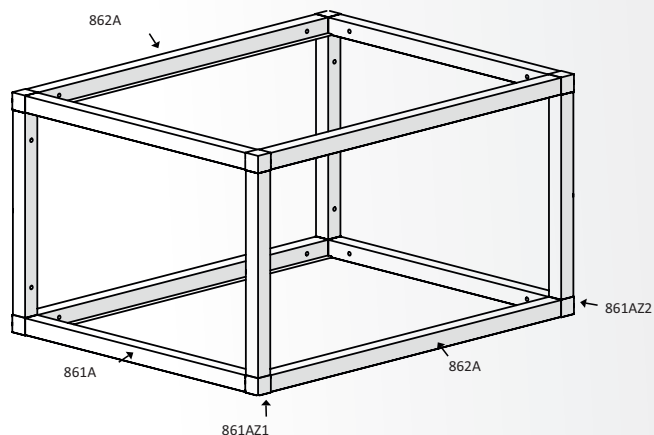

Profile are also available in bars and this allows an utmost customization thanks to a variety of accessories.

COMPONENTS



— 20,3 —

Code 861A
Aluminium Profile

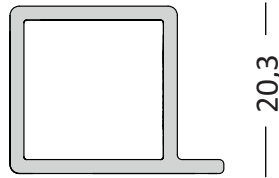

— 27,3 —

Code 862A
Aluminium Profile

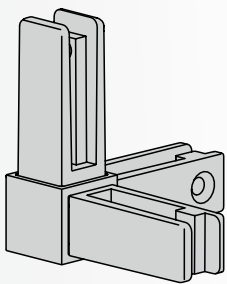
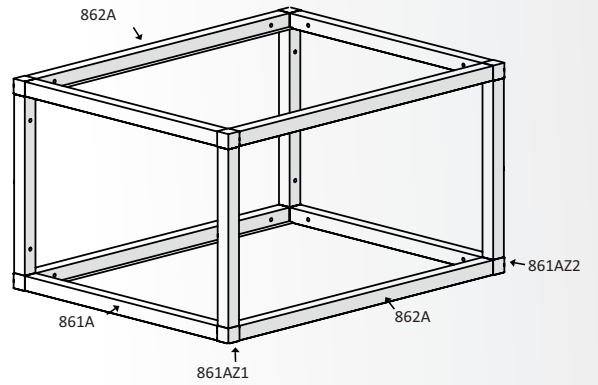

Code 861AZ1
Code 861AZ2
3-Way Corner Joint

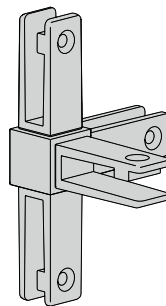

Code 861AZ3
Code 861AZ4
4-Way Corner Joint

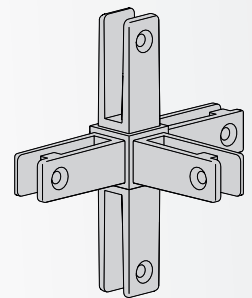

Code 861AZ5
5-Way Corner Joint

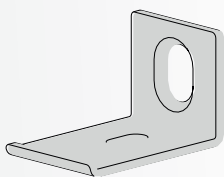

Code 862AF1
Metal Plate (Price Per Pair)



Code FERRAM
Profiles Special Screw

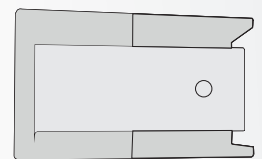

Code 861AP1
Drilling in ABS

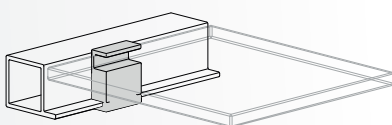

Code 862AK1
Glass Shelf Bracket

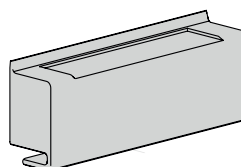

Code 862AK2
Shelf Spacer (Espesor 8 to 16 mm)

VARUN IMPEX

Address:

Gala No.1 & 4, Plot No.21, Papdy
Industrial Estate, Umela Phata,
Vasai Road (West), Palghar - 401207.
Mob.: +91 9167883194
Email: varunimpexkba@gmail.com
Website: www.varunimpex.in